

Measurement of Antenna Radiation Patterns
Laboratory Manual

Written by:

Vishal Bhavsar
Nicholas Blas
Huy Nguyen

Under the Guidance of:

Professor Alexander Balandin

Funding Provided By:

TRW Corporation

Background

by Nicholas Blas

Antennas are a fundamental component of modern communications systems. By definition, an antenna acts as a transducer between a guided wave in a transmission line and an electromagnetic wave in free space. Antennas demonstrate a property known as reciprocity, that is an antenna will maintain the same characteristics regardless if it is transmitting or receiving. When a signal is fed into an antenna, the antenna will emit radiation distributed in space a certain way. A graphical representation of the relative distribution of the radiated power in space is called a radiation pattern. The radiation pattern of the antenna is of principle concern when engineering a communications system. Let's assume that a signal needs to be sent from an antenna on the ground to a satellite in orbit. This would require a radiation pattern with the majority of its radiated power focused into orbit. If the antenna is not engineered to do so, contact cannot be established between the signal source and its target. There are many different ways to manipulate a radiation pattern to meet the demands of a specific task. These concepts are the principle focus of this lab assignment. Implementing this lab assignment, students will examine the radiation patterns of several antennas by hands on field testing. Only the most fundamental antennas were chosen for this lab assignment. This allows us to see visually how the most common types of real-world antenna designs function.

The following is a glossary of basic antenna concepts.

Antenna

An antenna is a device that transmits and/or receives electromagnetic waves. Electromagnetic waves are often referred to as radio waves. Most antennas are resonant devices, which operate efficiently over a relatively narrow frequency band. An antenna must be tuned to the same frequency band that the radio system to which it is connected operates in, otherwise reception and/or transmission will be impaired.

Wavelength

We often refer to antenna size relative to wavelength. For example: a half-wave dipole, which is approximately a half-wavelength long. Wavelength is the distance a radio wave will travel during one cycle. The formula for wavelength is shown on the next page.

$$\lambda = \frac{c}{f}$$

Where:

λ is the wavelength, and is expressed in units of length, typically meters, feet, or inches.

c is the speed of light, 29,979,307,700 centimeters/second, or 11,802,877,050 inches/second.

f is the frequency

For example: the wavelength in air at 825 MHz is: $\frac{11.803 \times 10^9 \text{ cm/sec.}}{825 \times 10^6 \text{ cycles/sec.}} = 14.307 \text{ in/cycle}$

Note: The length of a half-wave dipole is slightly less than a half-wavelength due to end effect. The speed of propagation in coaxial cable is slower than in air, so the wavelength in the cable is shorter. The velocity of propagation of electromagnetic waves in coax is usually given as a percentage of free space velocity, and is different for different types of coax.

Impedance Matching

For efficient transfer of energy, the impedance of the radio, the antenna, and the transmission line connecting the radio to the antenna must be the same. Radios typically are designed for 50 ohms impedance and the coaxial cables (transmission lines) used with them also have a 50 ohm impedance. Efficient antenna configurations often have an impedance other than 50 ohms, some sort of impedance matching circuit is then required to transform the antenna impedance to 50 ohms.

VSWR and Reflected Power

The Voltage Standing Wave Ratio (VSWR) is an indication of how good the impedance match is. VSWR is often abbreviated as SWR. A high VSWR is an indication that the signal is reflected prior to being radiated by the antenna. VSWR and reflected power are different ways of measuring and expressing the same thing. A VSWR of 2.0:1 or less is considered good. Most commercial antennas, however, are specified to be 1.5:1 or less over some bandwidth. Based on a 100 watt radio, a 1.5:1 VSWR equates to a forward power of 96 watts and a reflected power of 4 watts, or the reflected power is 4.2% of the forward power.

Bandwidth

Bandwidth can be defined in terms of radiation patterns or VSWR/reflected power. The definition used in this book is based on VSWR. Bandwidth is often expressed in terms of percent bandwidth, because the percent bandwidth is constant relative to frequency. If bandwidth is expressed in absolute units of frequency, for example MHz, the bandwidth is then different depending upon whether the frequencies in question are near 150, 450, or 825 MHz. A mathematical analysis of bandwidth is provided on the next page.

Percent bandwidth is defined as:

$$BW = 100 \frac{F_H - F_L}{F_C} \text{ where:}$$

F_H is the highest frequency in the band

F_L is the lowest frequency in the band

$$F_C \text{ is center frequency of the band} \quad F_C = \frac{F_H + F_L}{2}$$

Example: If you need an antenna that operates in the 150 - 156 MHz band, you need an antenna that covers at least a $\frac{156-150}{153} \cdot 100 = 3.9\%$ bandwidth.

The problem might need to be worked a different way, if the antenna is tuned to 460 MHz and provides a 1.5:1 VSWR bandwidth of 5%, what are F_L and F_H . The equations above can be solved for F_H and F_L :

$$F_H = F_C \left(1 + \frac{BW}{200}\right) \text{ and } F_L = F_C \left(1 - \frac{BW}{200}\right)$$

Plugging the numbers into the equations: and the answers are

$$F_H = 460 \left(1 + \frac{5}{200}\right) = 471.5 \text{ MHz}$$

$$F_L = 460 \left(1 - \frac{5}{200}\right) = 448.5 \text{ MHz}$$

Directivity and Gain

Directivity is the ability of an antenna to focus energy in a particular direction when transmitting or to receive energy better from a particular direction when receiving. The relationship between gain and directivity: $Gain = efficiency/Directivity$. We see the phenomena of increased directivity when comparing a light bulb to a spotlight. A 100 watt spotlight will provide more light in a particular direction than a 100 watt light bulb, and less light in other directions. We could say the spotlight has more "directivity" than the light bulb. The spotlight is comparable to an antenna with increased directivity. An antenna with increased directivity is hopefully implemented efficiently, is low loss, and therefore exhibits both increased directivity and gain.

Gain is given in reference to a standard antenna. The two most common reference antennas are the isotropic antenna and the resonant half-wave dipole antenna. The isotropic antenna radiates equally well in "all" directions. Real isotropic antennas do not exist, but they provide useful and simple theoretical antenna patterns with which to compare real antennas. An antenna gain of 2 (3 dB) compared to an isotropic antenna would be written as 3 dBi. The resonant half-wave dipole can be a useful standard for comparing to other antennas at one frequency or over a very narrow band of frequencies. To compare the dipole to an antenna over a range of frequencies requires an adjustable dipole or a number of dipoles of different lengths. An antenna gain of 1 (0 dB) compared to a dipole antenna would be written as 0 dBd.

Gain Measurement

One method of measuring gain is by comparing the antenna under test against a known standard antenna. This is technically known as a gain transfer technique. At lower frequencies, it is convenient to use a 1/2-wave dipole as the standard. At higher frequencies, it is common to use a calibrated gain horn as a gain standard, with gain typically expressed in dBi.

Another method for measuring gain is the 3 antenna method. Transmitted and received power at the antenna terminals is measured between three arbitrary antennas at a known fixed distance. The Friis transmission formula is used to develop three equations and three unknowns. The equations are solved to find the gain expressed in dBi of all three antennas.

Antenna Placement

Correct antenna placement is critical to the performance of an antenna. An antenna mounted on the roof will function better than the same antenna installed on the hood or trunk of a car. Knowledge of the vehicle may also be an important factor in determining what type of antenna to use. You do not want to install a glass mount antenna on the rear window of a vehicle in which metal has been used to tint the glass. The metal tinting will work as a shield and not allow signals to pass through the glass. When installing antennas at a base station, a stainless steel mast should be used to properly pass stray RF current away from the antenna and provide proper support.

Radiation Patterns

The radiation or antenna pattern describes the relative strength of the radiated field in various directions from the antenna, at a fixed or constant distance. The radiation pattern is a "reception pattern" as well, since it also describes the receiving properties of the antenna. The radiation pattern is three-dimensional, but it is difficult to display the three-dimensional radiation pattern in a meaningful manner, it is also time consuming to measure a three-dimensional radiation pattern. Often radiation patterns are measured that are a slice of the three-dimensional pattern, which is of course a two-dimensional radiation pattern which can be displayed easily on a screen or piece of paper. These pattern measurements are presented in either a rectangular or a polar format.

Absolute and Relative Patterns

Absolute radiation patterns are presented in absolute units of field strength or power. Relative radiation patterns are referenced in relative units of field strength or power. Most radiation pattern measurements are relative pattern measurements, and then the gain transfer method is then used to establish the absolute gain of the antenna.

Near-Field and Far-Field Patterns

The radiation pattern in the region close to the antenna is not exactly the same as the pattern at large distances. The term near-field refers to the field pattern that exists close to the antenna; the term far-field refers to the field pattern at large distances. The far-field is also called the radiation field, and is what is most commonly of interest. The near-field is called the induction field (although it also has a radiation component). Ordinarily, it is the radiated power that is of interest, and so antenna patterns are usually measured in the far-field region. For pattern measurement it is important to choose a

distance sufficiently large to be in the far-field, well out of the near-field. The minimum permissible distance depends on the dimensions of the antenna in relation to the wavelength. The accepted formula for this distance is:

$$r_{\min} = \frac{2D^2}{\lambda}$$

Where:

r_{\min} is the minimum distance from the antenna

D is the largest dimension of the antenna

λ is the wavelength

When extremely high power is being radiated (as from some modern radar antennas), the near-field pattern is needed to determine what regions near the antenna, if any, are hazardous to human beings.

Beamwidth

Depending on the radio system in which an antenna is being employed there can be many definitions of beamwidth. A common definition is the half power beamwidth. The peak radiation intensity is found and then the points on either side of the peak represent half the power of the peak intensity are located. The angular distance between the half power points traveling through the peak is the beamwidth. Half the power is -3dB , so the half power beamwidth is sometimes referred to as the 3dB beamwidth.

Antenna Pattern Types

Omnidirectional Antennas

For mobile, portable, and some base station applications the type of antenna needed has an omnidirectional radiation pattern. The omnidirectional antenna radiates and receives equally well in all horizontal directions. The majority of the antennas measured in the laboratory experiment are of this type, because of they are common-place in the real world. The gain of an omnidirectional antenna can be increased by narrowing the beamwidth in the vertical or elevation plane. The net effect is to focus the antenna's energy toward the horizon.

Selecting the right antenna gain for the application is the subject of much analysis and investigation. Gain is achieved at the expense of beamwidth: higher-gain antennas feature narrow beamwidths while the opposite is also true.

Omnidirectional antennas with different gains are used to improve reception and transmission in certain types of terrain. A 0 dBd gain antenna radiates more energy higher in the vertical plane to reach radio communication sites that are located in higher places. Therefore they are more useful in mountainous and metropolitan areas with tall buildings. A 3 dBd gain antenna is the compromise in suburban and general settings. A 5 dBd gain antenna radiates more energy toward the horizon compared to the 0 and 3 dBd antennas to reach radio communication sites that are further apart and less obstructed. Therefore they are best used in deserts, plains, flatlands, and open farm areas. A picture demonstrating gain on a mobile antenna is provided on the next page.

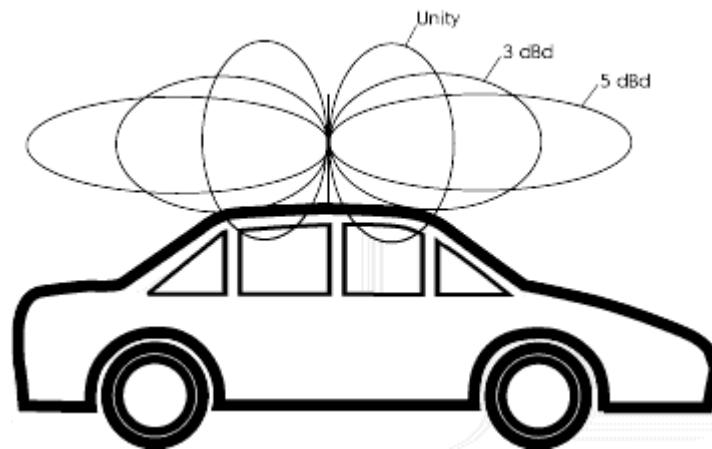

Directional Antennas

Directional antennas focus energy in a particular direction. Directional antennas are used in some base station applications where coverage over a sector by separate antennas is desired. Point to point links also benefit from directional antennas. Yagi and panel antennas are directional antennas. This lab experiment will demonstrate the principle of directionality through the use of a Yagi antenna.

Antenna Polarization

Polarization is defined as the orientation of the electric field of an electromagnetic wave. Polarization is in general described by an ellipse. Two often used special cases of elliptical polarization are linear polarization and circular polarization. The initial polarization of a radio wave is determined by the antenna that launches the waves into space. The environment through which the radio wave passes on its way from the transmit antenna to the receive antenna may cause a change in polarization.

With linear polarization the electric field vector stays in the same plane. In circular polarization the electric field vector appears to be rotating with circular motion about the direction of propagation, making one full turn for each RF cycle. The rotation may be right-hand or left-hand.

Choice of polarization is one of the design choices available to the RF system designer. For example, low frequency (< 1 MHz) vertically polarized radio waves propagate much more successfully near the earth than horizontally polarized radio waves, because horizontally polarized waves will be canceled out by reflections from the earth. Mobile radio systems waves generally are vertically polarized. TV broadcasting has adopted horizontal polarization as a standard. This choice was made to maximize signal-to-noise ratios. At frequencies above 1 GHz, there is little basis for a choice of horizontal or vertical polarization, although in specific applications, there may be some possible advantage in one or the other. Circular polarization has also been found to be of advantage in some microwave radar applications to minimize the "clutter" echoes received from raindrops, in relation to the echoes from larger targets such as aircraft. Circular polarization can also be used to reduce multipath. The majority of the antennas utilized in this experiment are vertically polarized because of their predominance in antenna applications.

Description of Antennas Available for this Laboratory Assignment

In order to place emphasis on the fundamental background information just provided, five antennas were selected to experiment with: the half-wave dipole, 3 element Yagi, quarter wave ground plane, 5/8 wave ground plane, and omni-angle antennas. The following is a detailed description of each of the antennas used in the experiment.

Half Wave Dipole

The half wave dipole is perhaps the simplest and most fundamental antenna design possible. Hertz used a dipole antenna during his initial radio experimentation. This is why a dipole is often referred to as the “hertz dipole” antenna. The dipole is so practical that it is utilized (in some form) in at least half of all antenna systems used today. Here are some key principles of the dipole antenna:

- 1.) A dipole antenna is a wire or conducting element whose length is half the transmitting wavelength.

To calculate the length of a half wave dipole in free space, one may use the following equation:

$$\text{length (ft)} = 492 / \text{frequency (MHz)}$$

- 2.) A dipole antenna is fed in the center.

By using a piece of coaxial cable transmission line, one may feed the center conductor of a transmission line to a $\frac{1}{4}$ wavelength piece of wire. The outer shield or ground of the cable may be connected to the remaining $\frac{1}{4}$ wavelength piece of wire. Thus, you have a dipole antenna, fed in the center, with an overall length of $\frac{1}{2}$ wavelength. The total $\frac{1}{2}$ wavelength of wire is to be stretched out evenly, being perpendicular to the transmission line. How exactly does the signal come out of the cable and emanate from the wires into space? The $\frac{1}{4}$ wavelength wire which is fed by the center conductor of the transmission line is known as the hot portion. One quarter of the wave leaks from the attached wire, and the remaining quarter of the wave “hops” over to the grounded second $\frac{1}{4}$ wavelength wire. Since these two pieces of $\frac{1}{4}$ wavelength wire work together to emit the wave, we often refer to a dipole as a perfect resonant antenna. Why is this important? If an antenna is resonant, it will be matched to the transmission line and/or transmitter and the bulk of the signal will actually be transmitted, not reflected back and wasted as heat (i.e. Standing Wave Ratio SWR). It should be noted that a dipole has an impedance of 75 ohms, not 50 ohms. Ordinarily a mismatch could cause a problem, but the mismatch of 50 ohm cable feeding a 75 ohm antenna is minimal with a resultant SWR of 1.5:1. This corresponds to roughly a 5% waste of power.

3.) The dipole antenna has a unique radiation pattern.

The radiation pattern of a dipole antenna in free space is strongest at right angles to the wire. This pattern, when the antenna is positioned horizontally over the ground, resembles a figure eight. This figure eight pattern will be verified during the experiment. Let's assume we shift the antenna around and make it vertical (perpendicular to the ground). The ends of the wire which emit the least amount of energy are now directed towards both the earth and the sky. This results in a vertically polarized signal which is focused quite evenly across the reception zone. This brings up an important concept: antenna radiation patterns can be quite different horizontally and vertically. This concept will be verified when the dipoles are tested. Also, it is important to note that for a signal to be received effectively, the receiving antenna must be in the same plane as the transmitting antenna. If these are mismatched, a large portion of the signal will be lost or distorted. This concept will be verified as well.

4.) The dipole antenna is extremely flexible.

What changes can one make to a dipole to subsequently alter its radiation pattern? There are limitless modifications that can be made. For instance: Instead of keeping the $\frac{1}{2}$ wavelength elements perpendicular to the transmission line, let's bend them or "slope" them by 45 degrees. This simple change will modify the radiation pattern. What happens when we stack two dipoles on top of each other, separated by one full wavelength of space, and feed them in phase? This is known as a stackable phased array. This focuses more of the radiated power towards the horizon, where it is most useful. Stacking antennas for this purpose produces gain. Gain is useful because it improves the strength of the signal that is transmitting or receiving. For instance: if a signal is fed into an antenna with 3db (decibels) of gain. The transmitted signal will appear on the receiving end twice as strong as it would have been if the transmitting antenna had no gain. This can be quite beneficial to a communications engineer. It is very costly to produce high powered transmitters. Gain offers a good compromise. A 10 watt signal fed into an antenna with 3dB of gain will result in an effective radiated power (ERP) of 20 watts. By introducing an antenna with gain, an engineer can avoid having to use a 20 watt signal and an antenna with no gain. Examples of gain will be demonstrated in the lab. Gain and radiation patterns go hand in hand. If we were to place three dipoles in a row, the radiation pattern would be projected into a forward direction. This is known as forward gain.

On the next page is a picture of the ideal radiation pattern of a half-wave dipole in free space. This is the radiation pattern with the antenna mounted horizontally. Observe the figure eight pattern. Notice the dotted lines. The pattern is a little distorted because of the antenna mast and ground distort the pattern. It is inevitable that external factors will make the real world radiation patterns less than perfect, however, the antenna radiation patterns will still resemble their theoretical counterparts.

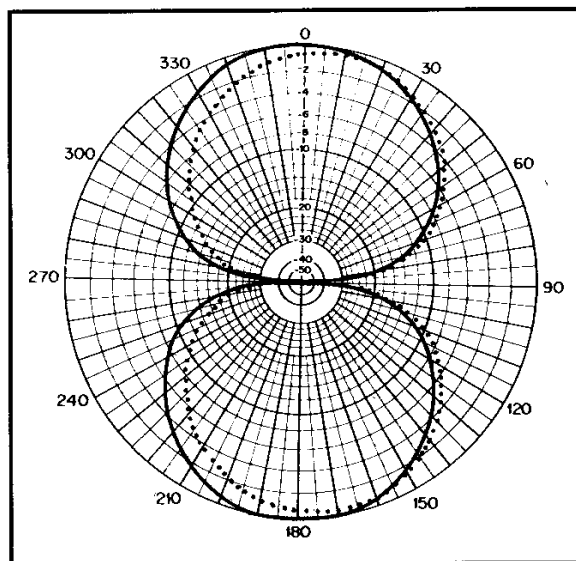

This is a picture of a dipole antenna fed by a transmission line. The picture demonstrates the simplicity of the dipole design. All one needs to construct a dipole is some wire and a length of coaxial cable. Notice that there are multiple lengths of wire each equal to $\frac{1}{2}$ wavelength. This is known as a multi-band dipole. It is the equivalent of connecting dipoles in parallel which are tuned to different frequencies.

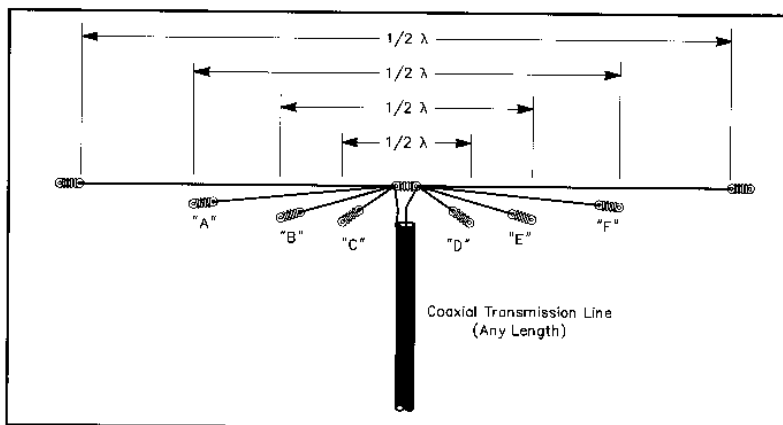

The picture on the next page represents a sloped dipole or inverted V dipole. When the dipole is bent, the radiation pattern shifts and the impedance changes upward to around 450 ohms. This allows the engineer to use parallel transmission line cable rather than coaxial cable, because such cable generally has an impedance of 300-450 ohms and is very inexpensive.

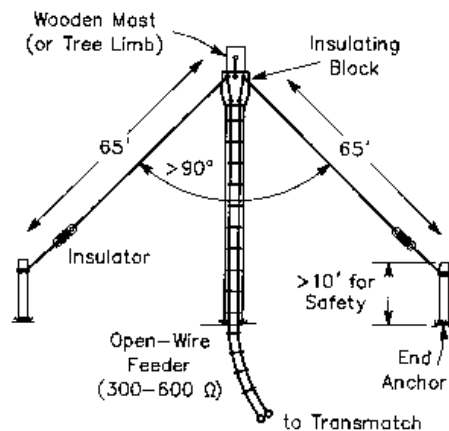

Multiband "Inverted V"

The following are digital pictures of the dipole antenna used in the experiment. Look closely at its appearance and compare it to the fundamental information established earlier in the background of the lab report. This particular dipole is constructed of high grade aluminum and will be the dipole used for measurement purposes. You will need to mount the dipole exactly as shown, keeping the black stub (gamma match) facing up in the vertical mode. One picture shows the antenna in the vertical position, the other in the horizontal position.

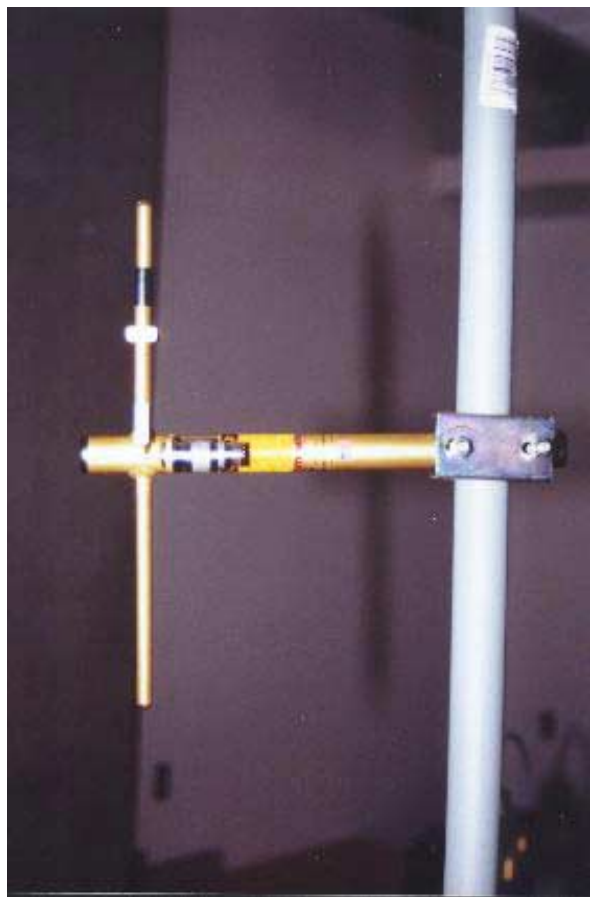

The pictures below are of another dipole antenna. This dipole antenna is the antenna used for the transmitter in the experiment. A dipole was constructed out of PVC pipe so that it could easily be turned between horizontal and vertical to accommodate the different types of antennas being tested. It is shown in both the horizontal and vertical positions. To change between vertical and horizontal in the field, simply grab the horizontal PVC pipe coming off of the mast and twist it 90 degrees so that the antenna is either facing up and down (vertical) or left and right (horizontal). When it is vertical, make sure than the arrows drawn on the pipe are facing the sky.



3 Element Yagi

The Yagi antenna is used frequently because it offers gain and directivity. The Yagi antenna was developed by a Japanese engineer Yagi-Uda. Its design is based exclusively on dipoles. A quick glance at a standard TV antenna will show a series of dipoles in parallel to each other with fixed spacing between the elements. The number of elements used will depend on the gain desired and the limits of the supporting structure. A three element Yagi consists of a director, a driven element, and a reflector. Below is a picture of how these elements are configured:

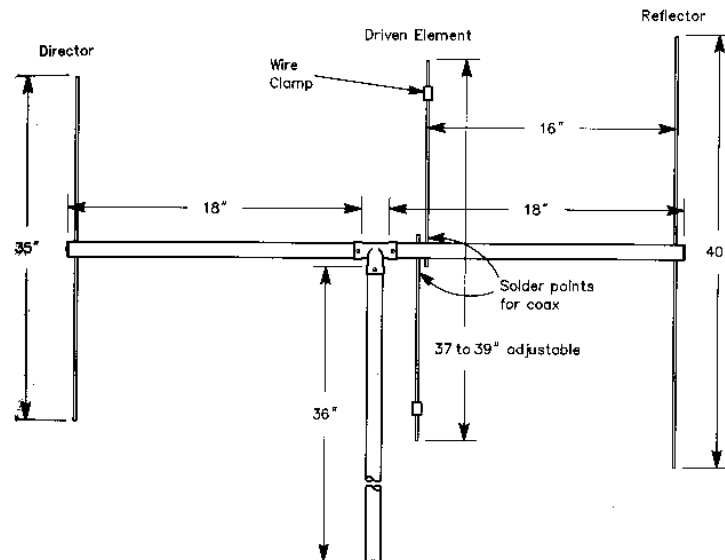

Notice that the driven element is in the center and is nothing more than a center fed dipole. To the right of the driven element is the reflector. The reflector is slightly longer than the driven element to allow for proper tuning. The reflector is simply a passive piece of metal slightly longer than $\frac{1}{2}$ wavelength. At the front of the antenna is the director. It is electrically and physically shorter than the driven element. These elements work together to project a radiation pattern in the forward direction. This forward radiation pattern has gain. This type of system is ideal for television broadcasts. Let's assume you want to receive CBS's channel 2 signal from Mount Wilson. You could simply use a pair of rabbit ears (which is a dipole) to pick up the signal, but it probably would come in snowy. This is where a Yagi can come into play. A three element Yagi in free space can have a maximum gain of around 9dB. This means the signal will be amplified by about 16 times by the antenna. Also, the radiation pattern of the antenna tends to transmit or receive the bulk of the signal from the forward direction. Thus, aiming a Yagi at Mount Wilson would receive a strong focused signal, resulting in a much better picture. Like a dipole, a Yagi can be placed either vertically or horizontally. Although this could shift the radiation pattern slightly, the concepts of gain and directivity still remain.

Below is a picture of the radiation pattern of a three element Yagi in free space. Is it what you would expect from the information provided about Yagi antennas? Notice the principles of forward gain and directivity? Note: the forward facing pattern is known as the forward lobe. The backward facing pattern is known as the backward lobe. This is an ideal radiation pattern measured in a special chamber. When the Yagi antenna is tested in the experiment, the radiation pattern will not be perfectly aligned with the theoretical model, but the concepts of gain and directivity should be evident from the plot.

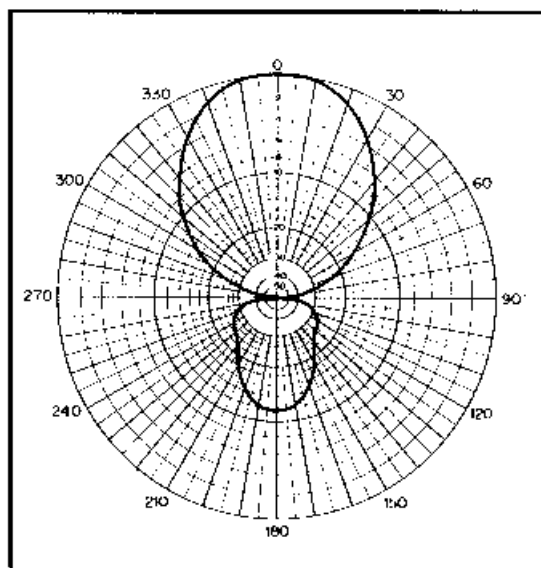

A Yagi antenna often has an impedance of 200 ohms and needs to be matched down to standard 50 ohm cable. A method used to correct this mismatch is to insert a gamma match between the feedline and the antenna. A picture of this match is shown below.

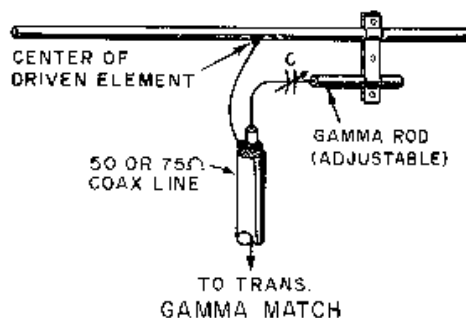

The picture below is of the Yagi antenna. Does it resemble the data in the background section? Observe the way the antenna is mounted. The antenna is positioned slightly down the mast. Make sure you emulate this during the experiment. Also, observe that the gamma match (black cap) is facing upwards towards the sky. Make sure you emulate this as well.

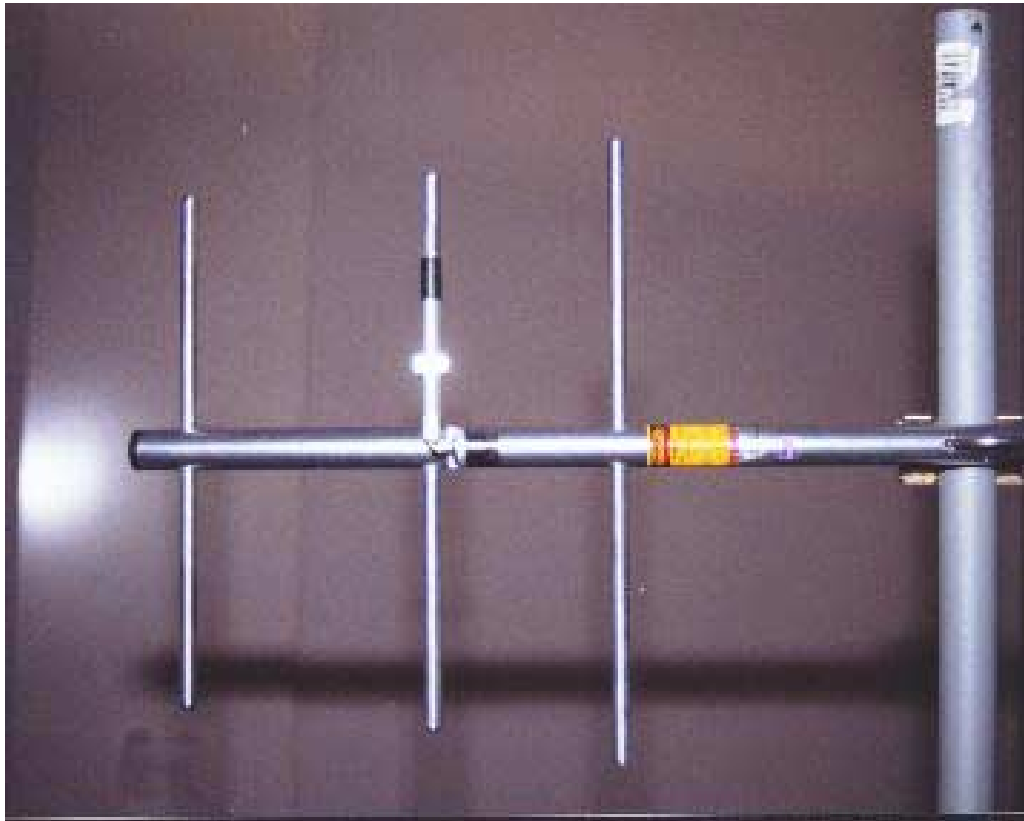

Quarter Wave Ground Plane

The $\frac{1}{4}$ wavelength ground plane antenna is very simple in its construction and is useful for local communications when size, cost, and ease of construction are important. This antenna is designed to transmit a vertically polarized signal, that is, the signal is transmitted perpendicular to ground. This antenna is a cousin to the common dipole antenna. It consists of a $\frac{1}{4}$ wave hot element similar to a dipole's, but instead of having one $\frac{1}{4}$ wave ground element in the same plane, it consists of 3-4 $\frac{1}{4}$ wave ground elements bent 45 degrees down. This set of elements is known as a ground plane. This can be conceptualized in the picture below:

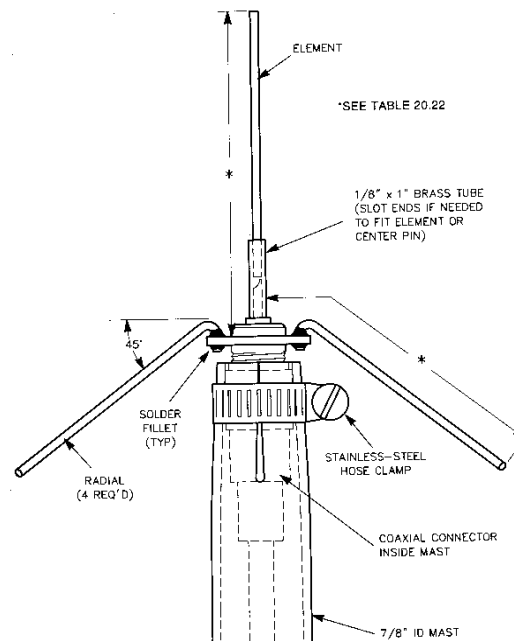

This type of antenna has several characteristics that make it worthy of this experiment. First of all, a quarter wave ground plane is very close to what we call an isotropic radiator. An isotropic radiator is an antenna which has no gain and a near equally distributed circular radiation pattern. A quarter wave ground plane matches this description almost perfectly. This is a simple and effective antenna that can capture a signal equally from all directions. Its real world applications are widespread. The 27" antenna on an automobile is a $\frac{1}{4}$ wavelength antenna. The antenna receives FM radio signals equally from any direction and uses the metal body of the car as the ground plane. The short antenna stub in a cellular phone is a $\frac{1}{4}$ wavelength antenna which uses the metal back plate of the phone as the ground plane. These are just a few of the many applications which require an antenna like the quarter wave ground plane.

This is a picture of the quarter wavelength antenna used in the experiment. This antenna uses three ground radials. How well does it resemble the background data? Theoretically, one should expect this antenna to radiate an almost circular radiation pattern. This will be investigated through experimentation. Mount the antenna as shown.



5/8 Wave Ground Plane

The 5/8 wave antenna is very similar to a 1/4 wave ground plane antenna. Something interesting happens when you lengthen the transmitting element to 5/8 wavelength. When this is done, the antenna focuses more energy towards the horizon, thus not wasting any energy towards unwanted areas like the sky. Compared to the 1/4 wave ground plane antenna mentioned previously, a 5/8 wave antenna has 3dB of gain. This means that the antenna's design will effectively double the power being applied to it. This is why the 5/8 wave antenna is very popular in modern communications design. It broadcasts a signal somewhat evenly over an area, but that area is exposed to a much more focused and powerful radiation pattern. The theoretical radiation pattern of this antenna type should resemble a three-leaf clover. This antenna uses three ground radials like the quarter wavelength antenna. Due to the gain characteristics of this antenna, there will be an evident power increase around the areas between the ground radials. This should be visible during the experiment and resemble the clover pattern mentioned above. Like a dipole, these antennas can be stacked for even greater gain. A great majority of base station antennas used for police communications and ham radio communications are of this type.

Its construction is simple, but there is a prime difference between it and a 1/4 wave ground plane. A 1/4 wave antenna just happens to be of the same impedance (50 ohms) as most of the transmitters and transmission lines used in communications. When the element is lengthened to 5/8 wave, the impedance increases dramatically, making it impractical to feed. How does an engineer utilize the benefit of this antenna design if it isn't a perfect match? Incidentally, the matching is quite simple. If you insert an inductor, also known as a loading coil, in series with the transmission line and the feedpoint of the 5/8 wave antenna element, you can match the impedance of the transmission line with the impedance of the antenna. The inductor will allow the current to "surge" up and balance out among the element. Below is a picture of what this looks like:

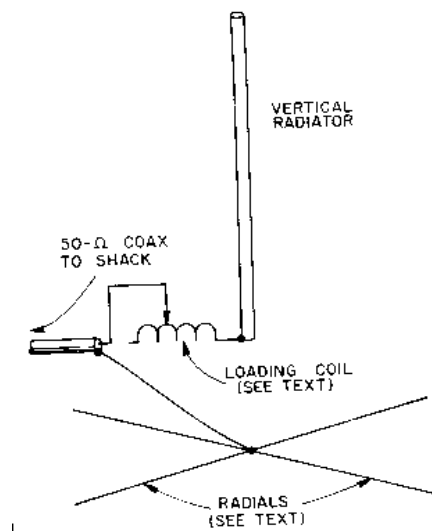

This is a digital picture of the $5/8$ wave antenna used in the experiment. You may have noticed that this antenna is physically longer than the quarter wave ground plane. This is due to the fact that this antenna is a dual-band antenna. It functions as a $5/8$ wave antenna @ 450 MHz and functions as a $1/4$ wave antenna @ 150 MHz. Ham radio operators find this beneficial because they use both 150 and 450 MHz to operate on. Is the picture of the antenna similar to what you would expect from the background information? Mount the antenna as shown.



OmniAngle Horizontal Loop Antenna

This is perhaps the most unique antenna of all. You may have noticed that out of all the antennas utilized in the experiment, none of them produce an equally distributed radiation pattern in the horizontal mode (parallel to the earth). The dipole can produce a pattern horizontally, but its shape resembles a figure eight, which is far from a “perfect circle”. The Yagi antenna is too directional to offer this option. The quarter wave ground plane antenna offers a near circular radiation pattern, but it is vertically polarized, not horizontally polarized. This is where the omniangle antenna comes into play.

The OmniAngle antenna can be described as a halo or loop antenna, because the antenna elements loop around towards their ends. We can describe this as a triangular dipole, because the elements, coupled with the base, form a triangle. Halo or loop antennas attempt to achieve an omni pattern by shortening a half wave dipole and forming it into a loop. Resonance is restored by capacity loading the far ends of the loop. The intent is to equally distribute current throughout the length of the antenna. Still, the current diminishes towards the end resulting in an egg shaped pattern. The other side effect of shortening is a severe reduction in usable bandwidth and a susceptibility to detuning with rain. The OmniAngle antenna is approximately 30% longer than a half wave. It is this electrical length in combination with the isosceles triangle shape that yields a near perfect omnidirectional pattern, much wider bandwidth, and considerably less rain detuning. Recent independent anechoic chamber testing confirms the superior pattern and gain over round and square style loops.

Because the antenna is longer than a half wave, it is no longer resonant (not matched to the transmission line). There is an attached matchbox consisting of a capacitor inductor network that effectively converts the feedpoint impedance (approx. $10+j90$ Ohms) to 50 ohms resistive. Finally, a Teflon current mode balun ensures equal current to both sides of the antenna. A balun, also known as a balanced unbalanced transformer, can work in conjunction with matchboxes to completely equalize out the impedance mismatches that exist between the transmission line and the antenna.

The following is a digital picture of the OmniAngle antenna. Does it seem to correspond to what you've read in the background data? The manufacturer claims that this antenna produces a near perfect circular horizontal radiation pattern. The experiment will either prove or disprove those claims. Mount the antenna as shown.

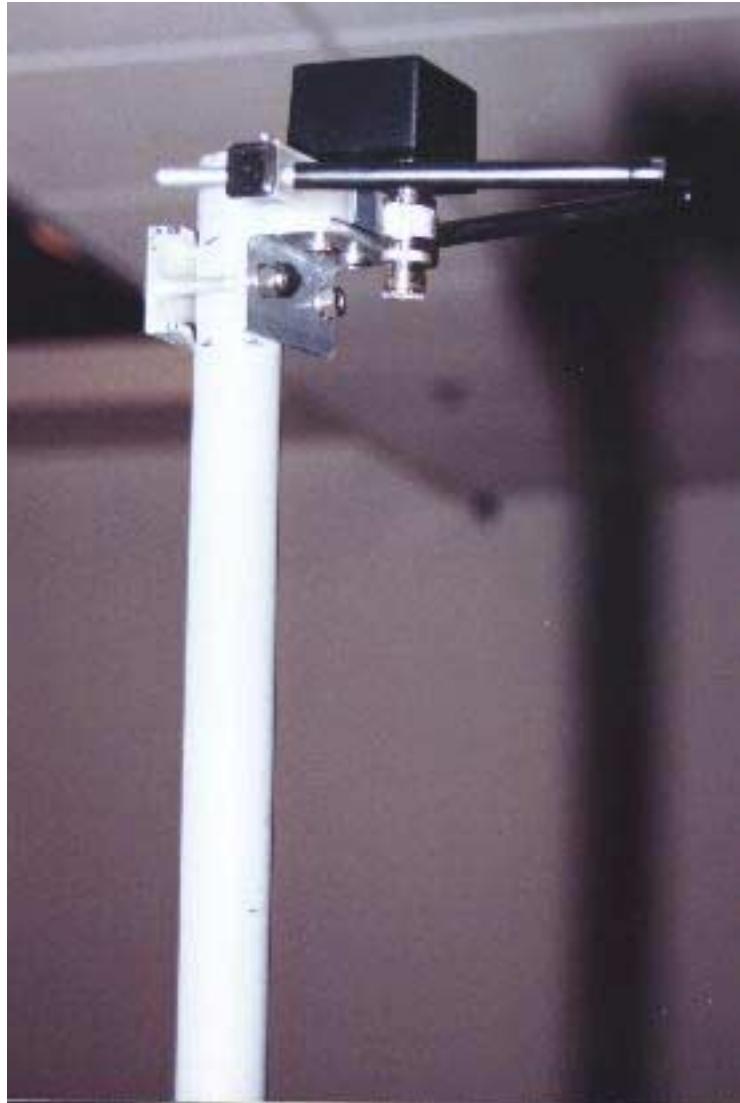

Equipment:

This lab requires a great deal of equipment. Below is a detailed list of the equipment necessary for the conduction of the experiment.

Ritron DTX-450 transceiver:

This unit is used to produce the signal which is transmitted through an antenna and subsequently received through another antenna whose radiation pattern is determined. This transmitter broadcasts a signal at 450.300 megahertz. The signal is frequency modulated and has a power output of 2 watts. A 450 megahertz transmitter is ideal for this experiment due to the fact that 450 megahertz antennas are both easy to obtain and take up relatively little space. This is a picture of the unit.



Icom communications receiver:

This unit is used to receive the broadcast signal @ 450 megahertz. The unit has a built in signal strength meter which allows us to calculate changes in dB. This can be converted to a two dimensional radiation pattern plot. The receiver is very versatile, in that it is capable of receiving a wide variety of signals on a fairly large frequency scale. This will make it useful in any type of experiment where radio signals need to be intercepted. A photo of the receiver is shown below.



Transmitting antenna apparatus:

This (as seen below) consists of a 3 foot tripod which supports a 7 ½ foot antenna mast. Attached to the top of this mast is a PVC dipole antenna. The dipole antenna is to always be used on this mast. The only thing we manipulate is the dipole's polarization (i.e. making the antenna vertical or horizontal). This is done by simply twisting the horizontal support pipe seen in the picture below.



Receiving antenna apparatus:

The receiving antenna apparatus (shown below) is very similar to the transmitting apparatus. It also consists of a tripod and mast. Its primary difference lies in the fact that an antenna rotator is attached to it (shown below as well). The antenna rotator is an electrical motor which rotates the antenna in controlled increments. This allows for accurate measurements of dB when the antenna is located on different axis locations. Unlike the transmitting apparatus, the antenna attached to it can be changed. You can technically attach any type of antenna you want to it and measure its radiation pattern following the procedure listed later in the manual.



Coaxial cable assemblies:

It would be impossible to connect these systems without proper cable. The cable used is high grade RG-8 coaxial cable which offers low signal loss. The picture below shows the cable.



Inline attenuator:

An inline attenuator is used between the 50 foot length of cable on the receiving apparatus and the Icom receiver. This is used in conjunction with the receiver's internal electronics to help plot the radiation pattern. The attenuator suppresses the signal down to a level that can be read on the receiver's own scale. The picture is shown below.



Power systems:

This experiment is to be conducted in the field. This requires a portable power system. We use a pair of marine batteries to accomplish this task. One of the batteries is connected directly to the Ritron transmitter for the transmitting apparatus. The other battery powers the Icom receiver on the receiving apparatus. Attached to this battery is a power inverter that converts 12 volts DC (battery) to 120 volts AC (home). This allows us to power the antenna rotator which would normally be used indoors.

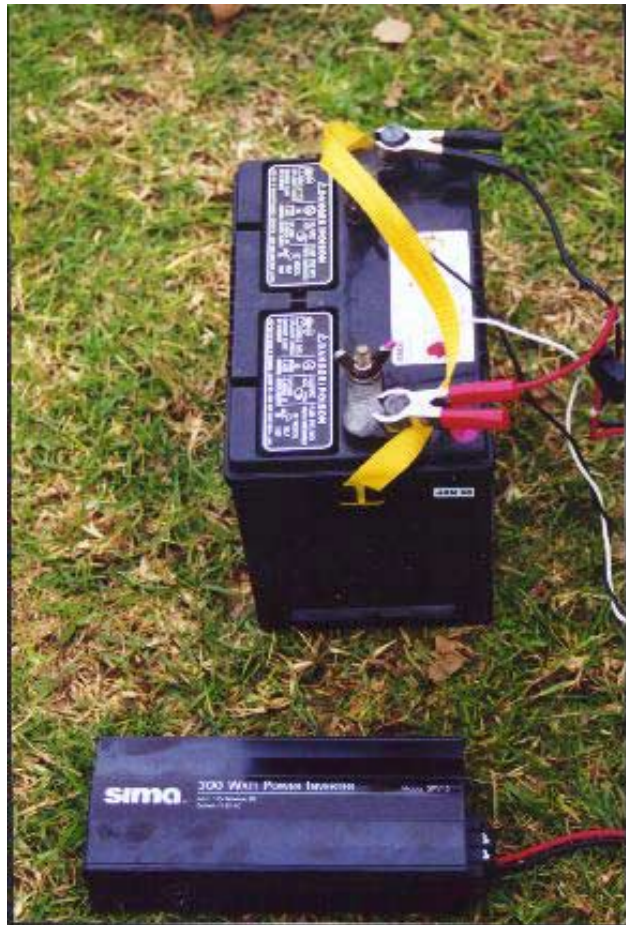

Wiring Diagram:

Please follow the photos below when assembling the equipment in the field.

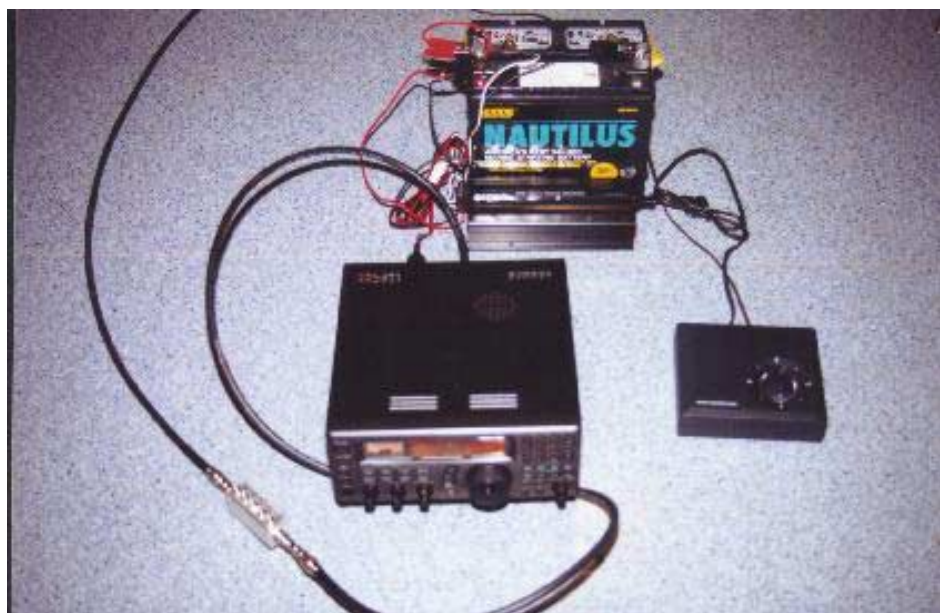
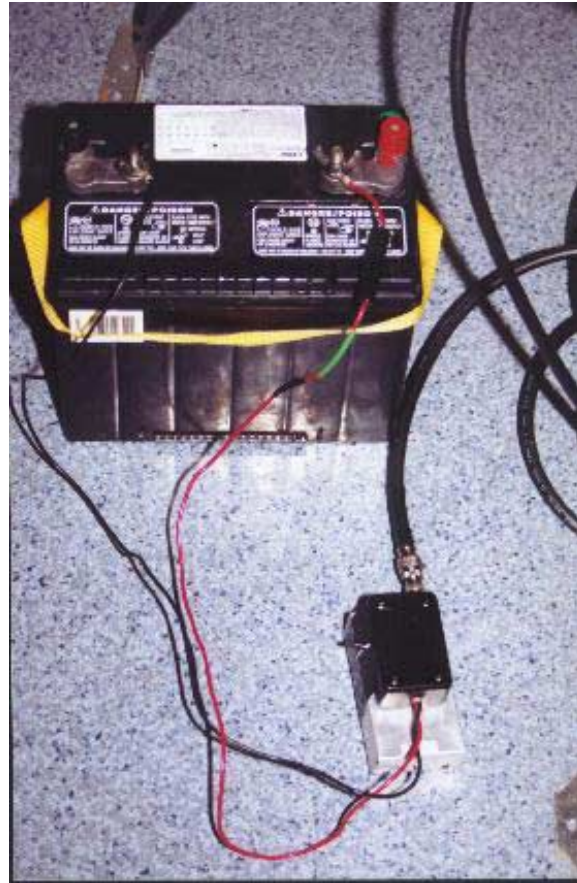

General Procedure:

(Refer to the hookup diagram on the preceding page if you have difficulty)

Radio Receiver (IC-R8500):

Connect the radio receiver to the 12 Volt battery.

Connect the antenna to the VHF/UHF female (center) jack on the back of the receiver.

Turn on the receiver.

Select the FM mode by pressing the FM button once.

Directly enter the frequency (450.3000) by using the numeric pad on the upper right corner of the receiver. Once the number is pressed, press “ENT” to enter the frequency.

Once the frequency is entered, lock the control panel holding in the “speech/lock” button until it beeps once.

Turn the AF Gain knob counter-clockwise to minimum.

Turn the Squelch knob to the center position.

Radio Transmitter (DTX-450):

Connect the transmitter to the coaxial cable hanging from the transmitting antenna apparatus.

Connect the transmitter to the 12 Volt battery.

Caution: DO NOT reverse the polarity. The metal casing of the transmitter is ground therefore DO NOT place the transmitter on the positive polarity of the battery.

After the transmitter is connected to the battery, there should be a faint light on the LED power indicator. If not, double check the battery connection and polarity.

When you are ready to transmit, flip the transmit switch located on the black box attached to the transmitter (the LED indicator should turn from dim to bright after this point). NOTE: The transmitter will turn itself off after 4 minutes of operation. Someone in the group will need to turn it back on periodically. You may keep the transmitter, the cable and the battery coupled together under the transmitting antenna apparatus. Simply have a group member run over to the area and reset the transmitter when needed.

NOTE: Separate the transmitting and receiving antenna apparatuses by ~ 60 feet.

Antenna Rotator:

Connect the DC to AC power inverter to the battery.

Caution: DO NOT touch the back of the rotator control box, the three terminals are at 115 Volts potential.

Plug the rotator control box into the inverter's AC outlet. Turn the control dial so that the line points to the North direction. If the dipole or Yagi antenna is being tested, make sure that the attached antenna is facing forward in the same direction as the transmitting antenna. Simply move the mast and tripod around until this is correct. Once this is in place, it is now in position for your zero degree measurement.

NOTE: You will want to stretch the brown antenna rotator cable and coaxial cable out and isolate yourself and the equipment as far away as possible from the receiving antenna apparatus. This is roughly a 40' distance.

Radiation Measurement:

Connect the external attenuator in series between the receiver and the antenna. There are five switches on the external attenuator. Each of the numbers below the switches represent the attenuation factor in dB. For example, if switch 1 and 8 are on, the total attenuation is $1\text{dB} + 8\text{dB} = 9\text{dB}$. If all of the switches are on, the attenuation factor will be 31dB.

After the antenna and the attenuator are connected to the receiver, the s-meter on the radio receiver should show the relative signal strength of the incoming signal. The attenuator's switches should be off at this point (pointed towards the numbers). If the signal strength on the receiver's meter is higher than 20dB, you will need to enable the 10 and/or 20dB internal attenuators on the receiver as well. The objective is to find the correct value of attenuation so that the signal meter on the receiver read a "7". Turn on the appropriate combination of the attenuator's switches so that the signal meter read a "7". Add up the dB levels from both the receiver's attenuators and the inline attenuator. Record this value for your 0 degree measurement.

Rotate the control knob on the control module in 11.25 degree increments (follow the markers on the rotator module). For each increment, adjust the necessary combination of attenuation factor, by turning on or off the appropriate switches, so that the receiver signal meter once again measures a "7". Record the value. Repeat the above process for each degree increment until you get back to 0/360 degrees. When you are finished and need to measure another antenna, return the knob back to the original 0 degree position.

Once the data is collected, use Matlab to plot the data. You may use the polar function. Remember to convert from degrees back to radians for this purpose. Matlab will automatically convert back to degrees when it plots the pattern.

Specific Procedures:

The general procedure has been outlined. There are, however, certain guidelines that should be followed that are specific to each antenna. Those procedures will be outlined below.

1.) Optional practice In-Lab testing procedure:

Before jumping out to the field, you may want to become familiar with the operation of the equipment before-hand. You may do the following:

a.) Verify the functionality of the transmitter and receiver:

Hook the receiver up to the battery or use its power supply.

Hook up the transmitter to the 12V regulated power supply.

Make sure the 12V power supply is turned off.

Make sure an antenna is connected to the transmitter.

Turn the receiver on. Tune it to 450.3000 MHz in FM mode.

Turn on the transmitter by first turning on the power supply and then flipping the transmitter's power switch. An LED light should glow brightly on the transmitter.

Is there a carrier signal on the receiver when the transmitter is on?

NEVER TURN ON THE TRANSMITTER WITHOUT AN ANTENNA

If the above procedures fail to work, double check your connections.

b.) Practice with the receiving antenna apparatus:

In this lab you be required to shift the PVC dipole transmitting antenna between the vertical and horizontal modes. You should get used to this procedure. Locate the transmitting antenna apparatus (the one with the PVC antenna attached to it). Tilt the mast down towards ground level. Twist the horizontal PVC shaft 90 degrees so that the attached metal antenna is vertical. There is an arrow drawn on PVC pipe that points to the sky. Make sure that arrow does point towards the sky. You will need the transmitting antenna to be vertical for most of the radiation pattern measurements. Photos of this antenna in both positions are located in the background section of the lab manual.

2.) Specific procedures for testing the dipole antennas:

You will be testing the dipoles initially. You should have two dipoles connected. The one on the transmitting antenna apparatus is made of PVC pipe and will be shifted between horizontal and vertical. The dipole on the receiving antenna apparatus is a professional grade dipole made of metal. This is the one whose radiation pattern is being plotted. The radiation pattern of the dipoles mounted vertically is to be tested first. Make sure the transmitting PVC dipole antenna is vertical (with the arrow pointing towards the sky). Mount the metal dipole in the vertical position as well, as seen in the background section of the lab manual. Make sure that the extra metal bar (gamma match) on the antenna is on the top side of the antenna, facing the sky.

Once you have both of the antennas mounted vertically, the cables connected to them and the remaining systems in place, it is time to take the readings. Follow the general procedure when doing this. Make sure the antenna is facing forward towards the transmitting antenna at your 0 degree position. Once complete, it is time to measure the dipoles radiation pattern when it is mounted horizontally. To do so, you must rotate the PVC dipole antenna so that it is positioned horizontally, as seen in the background section of the lab. Once this is done, you will be required to mount the metal receiving dipole horizontally as well. Simply duplicate the mounting picture in the background section. Once everything is re-mounted, follow the general procedure and take your readings. You should notice that these readings are slightly different from the last set. This is to be expected.

3.) Specific procedures for testing the Yagi antenna:

The Yagi antenna is to be tested after the dipole because its design is based heavily on the basic Hertz dipole. It will also expose you to a very different set of readings. You will notice some rapid changes in your measurements. This is normal, because the Yagi offers a very focused radiation pattern. The Yagi is a vertical antenna. When you install it on the receiving apparatus, be sure to follow the mounting picture in the background section of the lab. Also, make sure that the metal bar (gamma match) on the antenna is facing upwards.

Make sure the PVC dipole on the transmitting antenna apparatus is also in the vertical position, with the arrow pointed to the sky. You will want the Yagi to be facing forward towards the transmitting antenna when the rotator is at its 0 degree position. Follow the general procedure and take the readings.

4.) *Specific procedures for testing the 1/4 wave ground plane antenna.*

The quarter wave antenna is the first omnidirectional antenna used in the experiment. This is a vertical antenna, so make sure the transmitting dipole is in the vertical position (with the arrow pointed towards the sky). Mount the antenna in the same fashion as seen in the background section. Follow the general procedure outlined previously. Take the readings. You should notice a fairly consistent, almost circular pattern.

5.) *Specific procedures for testing the 5/8 wave ground plane antenna.*

Follow the same procedure as the 1/4 wave antenna. You should observe some signal peaks in your readings.

6.) *Specific procedures for testing the OmniAngle horizontal antenna.*

This is also an omnidirectional antenna, but the pattern is in the horizontal mode and, according to the manufacturer, will have a circular radiation pattern. Because this is a horizontal antenna, you will want to first orient the PVC transmitting dipole in the horizontal position. Make sure you mount the OmniAngle antenna the same way as the background photo. Follow the general procedure and catalog your readings.

Your Lab Report:

You should include the following in your lab report:

- 1.) For each antenna tested, you should include the graphical plots of the radiation patterns. Use Matlab to do this. Matlab's polar function can be manipulated to plot the dB levels every 11.25 degrees. Label each graph and include it in your report.

- 2.) Answer the following questions in your report:
 - a.) For the dipole testing, is there a distinctive difference among the radiation patterns between operating them when they are both in the vertical mode compared to when they are both horizontal? If so what is it? Do your results fall reasonably inline with the theoretical information in the background section of the lab? Do your results resemble those at the end of this manual? If there are any major differences, what do you attribute them to? Hint: pay close attention to things which could "interfere" with the patterns, i.e. weather, people, cars. Can you see why the dipole is used often by antenna engineers?

 - b.) For the Yagi testing, did the radiation pattern you found fairly demonstrate the principles of gain and directivity? Do your results fall reasonably inline with the theoretical information in the background section of the lab? Do your results resemble those at the end of this manual? If there are any major differences, what do you attribute them to? Hint: pay close attention to things which could "interfere" with the patterns. Explain what applications a Yagi antenna might be useful for.

 - c.) For the $\frac{1}{4}$ wave ground plane testing, would you concur that it is an omnidirectional antenna? Do your results fall reasonably inline with the theoretical information in the background section of the lab? Do your results resemble those at the end of this manual? If there are any major differences, what do you attribute them to? Hint: pay close attention to things which could "interfere" with the patterns. Explain what applications a $\frac{1}{4}$ wave ground plane antenna might be useful for.

 - d.) For the $\frac{5}{8}$ wave ground plane testing, would you concur that it is an omnidirectional antenna? Does this antenna seem to have higher dB levels (a stronger more focused pattern in certain areas) compared to the $\frac{1}{4}$ wave ground plane antenna? Does it seem reasonable that this antenna offers a small amount of gain? Do your results fall reasonably inline with the theoretical information in the background section of the lab? Do your results resemble those at the end of this manual? If there are any major differences, what do you attribute them to? Hint: pay close attention to things which could "interfere" with the patterns. Explain what applications a $\frac{5}{8}$ wave ground plane antenna might be useful for.

- e.) For the OmniAngle horizontal antenna, would you concur that it is an omnidirectional antenna? Does the manufacturer's claim that this antenna produces a "near perfect circle" radiation pattern accurate or at least semi-accurate? Do your results resemble those found at the end of this manual? If there are any major differences, what do you attribute them to? Hint: pay close attention to things which could "interfere" with the patterns. Explain what applications this antenna might be useful for.
- 3.) Also, please include an objective, equipment and procedure, raw data, and conclusion section in your report. How you do this is entirely at your discretion, however, you should formulate these on your own and not simply copy down what you find in this manual.
- 4.) Make sure and comment on this lab in your conclusion. What would you change about it? How could you make it more efficient? What were your likes and dislikes? What types of antennas would you like to test in a future lab? This lab is in its infancy and will most likely become a permanent part of the curriculum at UCR and possibly at other institutions. Your feedback is appreciated and will be integrated into any revisions of this lab.
- 5.) We hope you have become an expert on fundamental antenna radiation patterns. We also hope that you found this lab to be practical, hands-on, and useful in the "real world". This is the type of work you may end up doing in industry. The knowledge gained in this lab will give you good insight when it comes time to enter the job market.

Appendix:

I.) Radiation Pattern Plots

Radiation Pattern: Horizontal Dipole Antenna
theta = 11.25 degree increments, r = dB

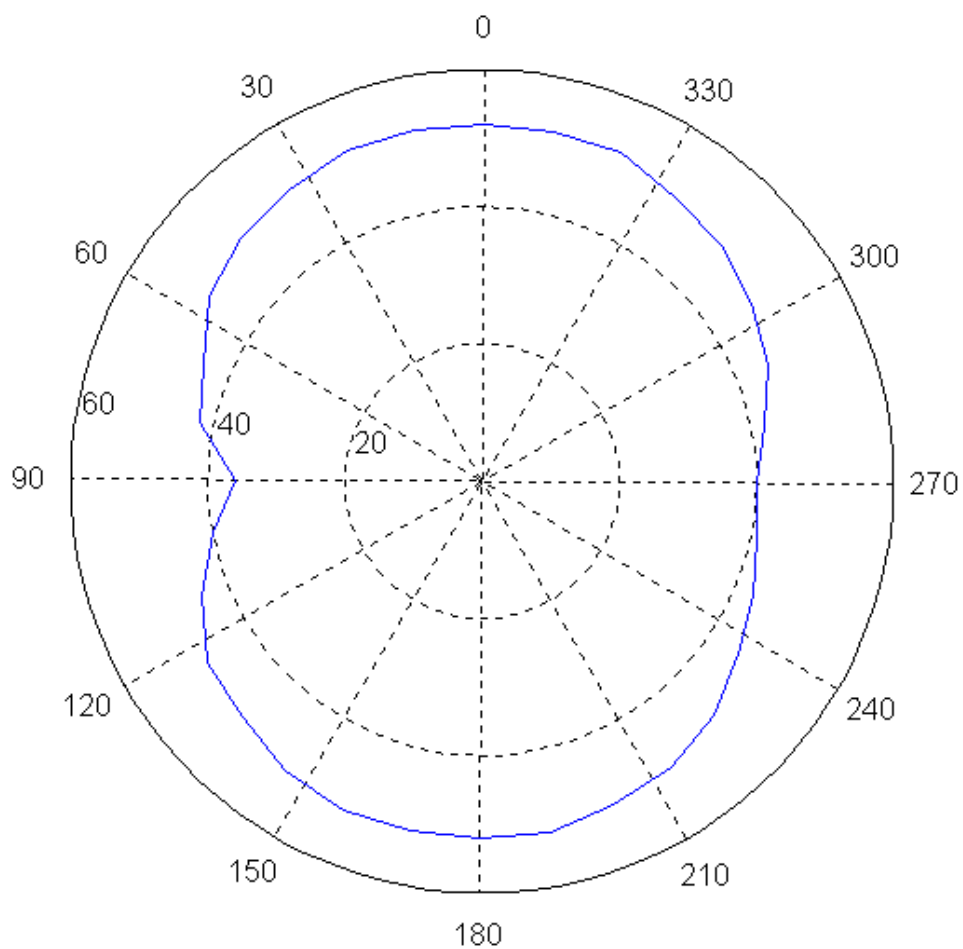

Observe the figure eight pattern. The smaller dB dip on the right is due to the gamma match.

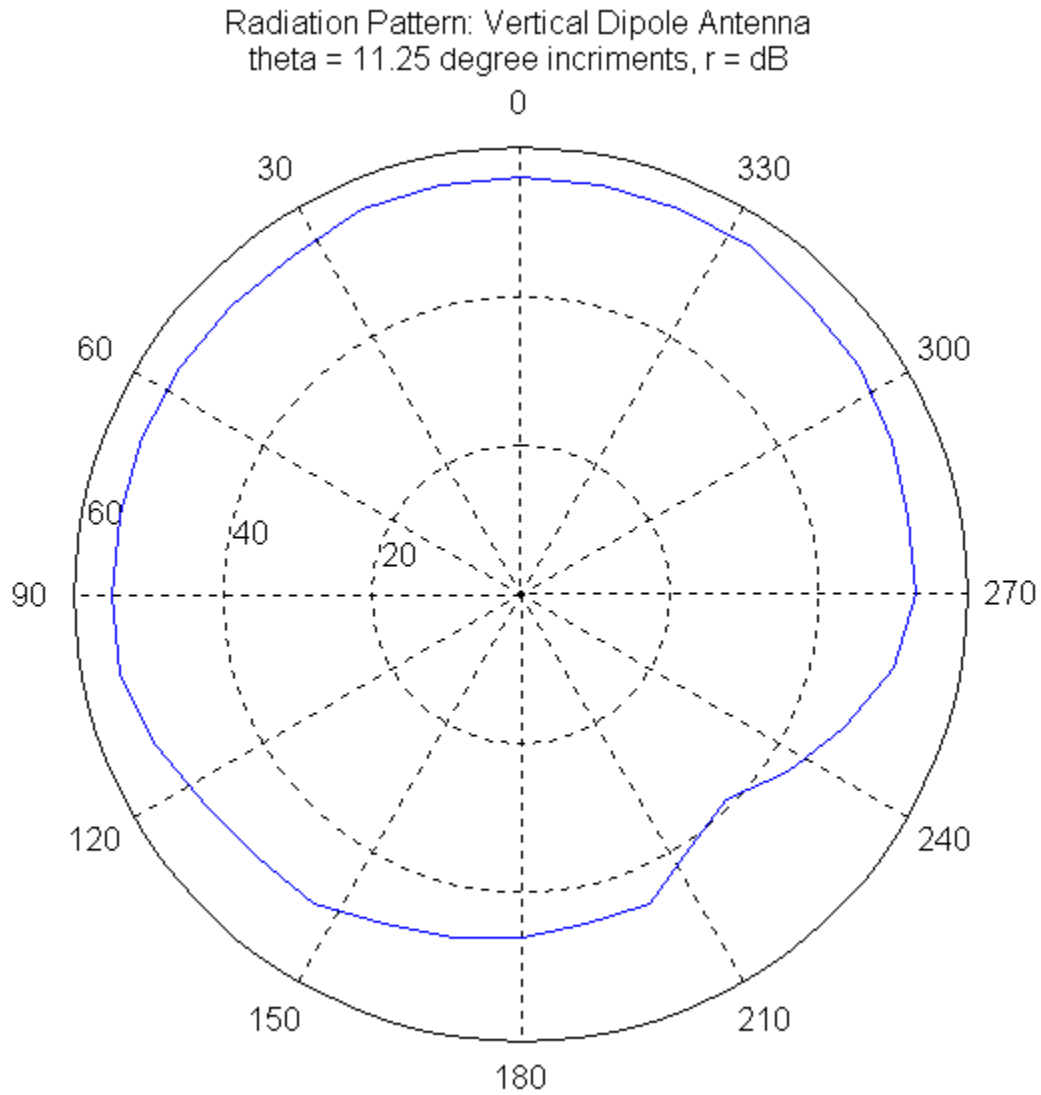

Observe the slightly directional circular pattern. The dip on the right is due to the gamma match.

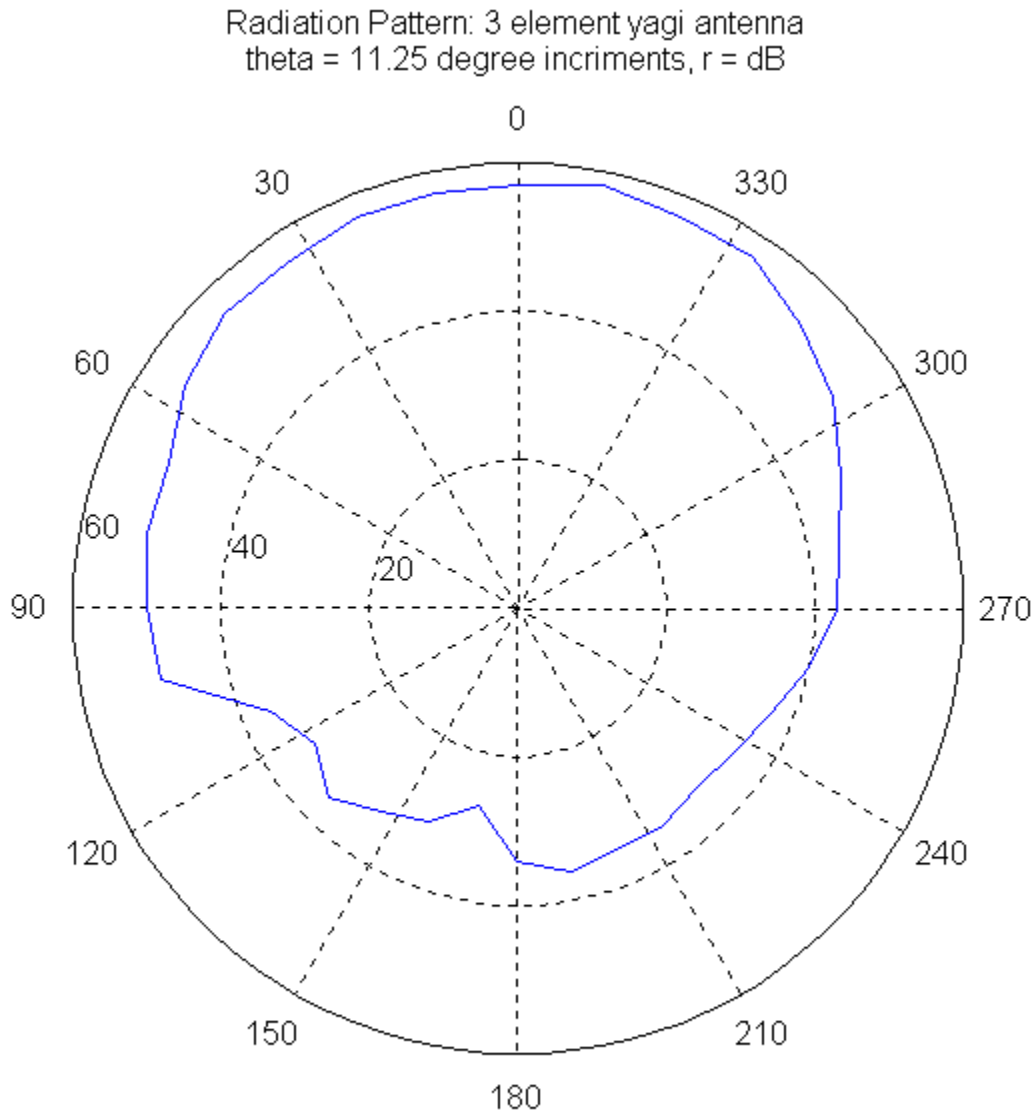

Observe the forward directive pattern. The signal dip on the lower left is from the gamma match.

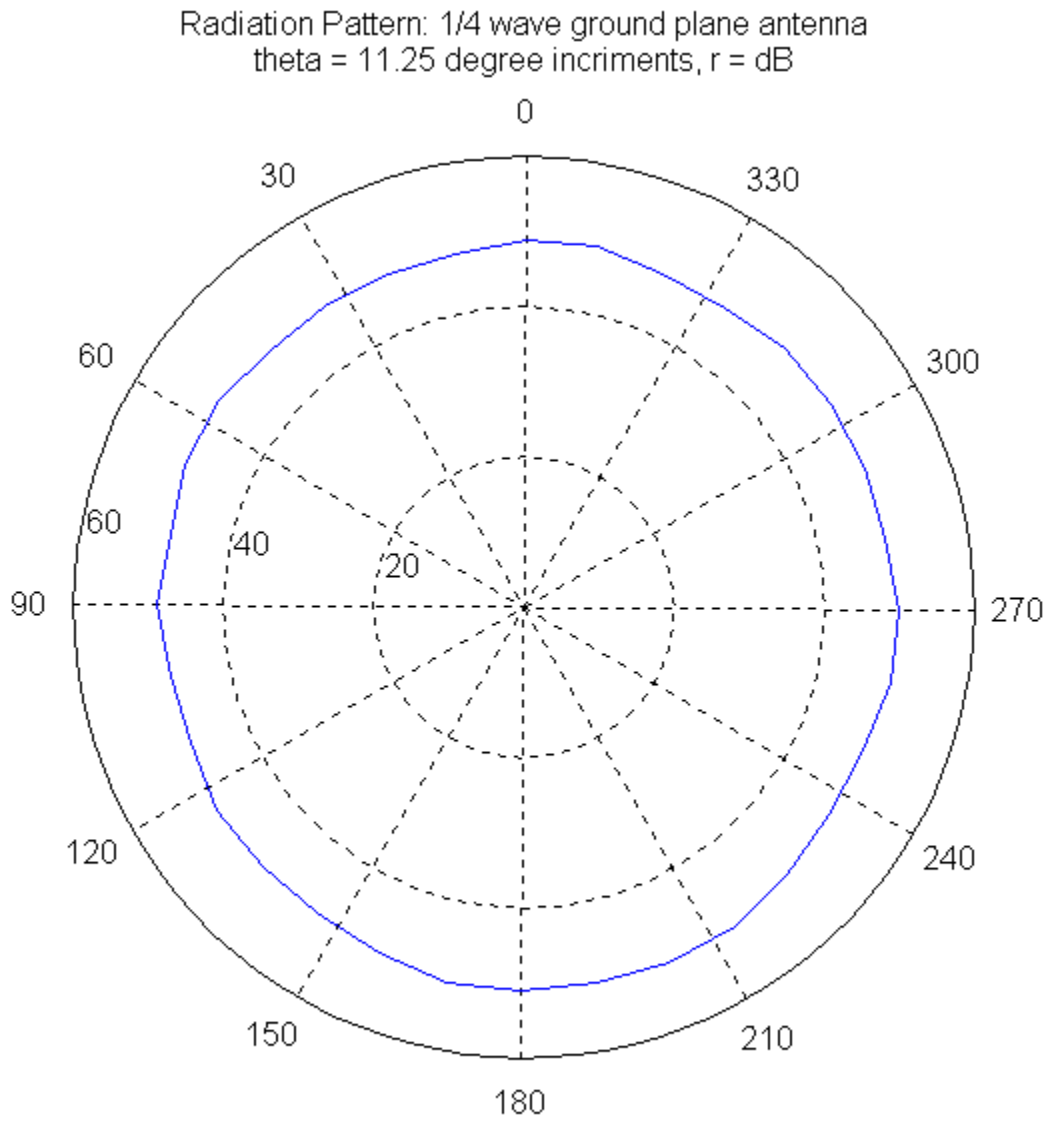

Observe the uniform circular pattern. The antenna is truly omni-directional and offers no gain.

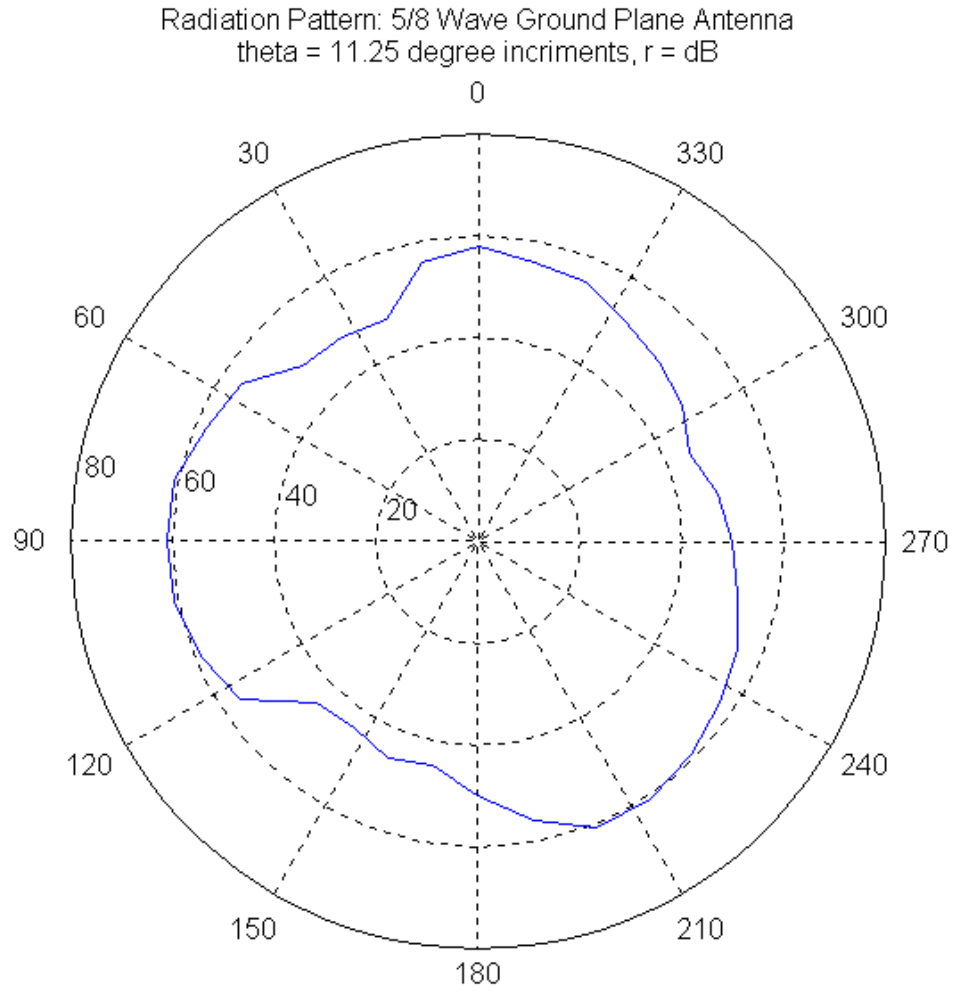

Observe the distinctive peaks of dB every 120 degrees. This is due to the gain characteristics.

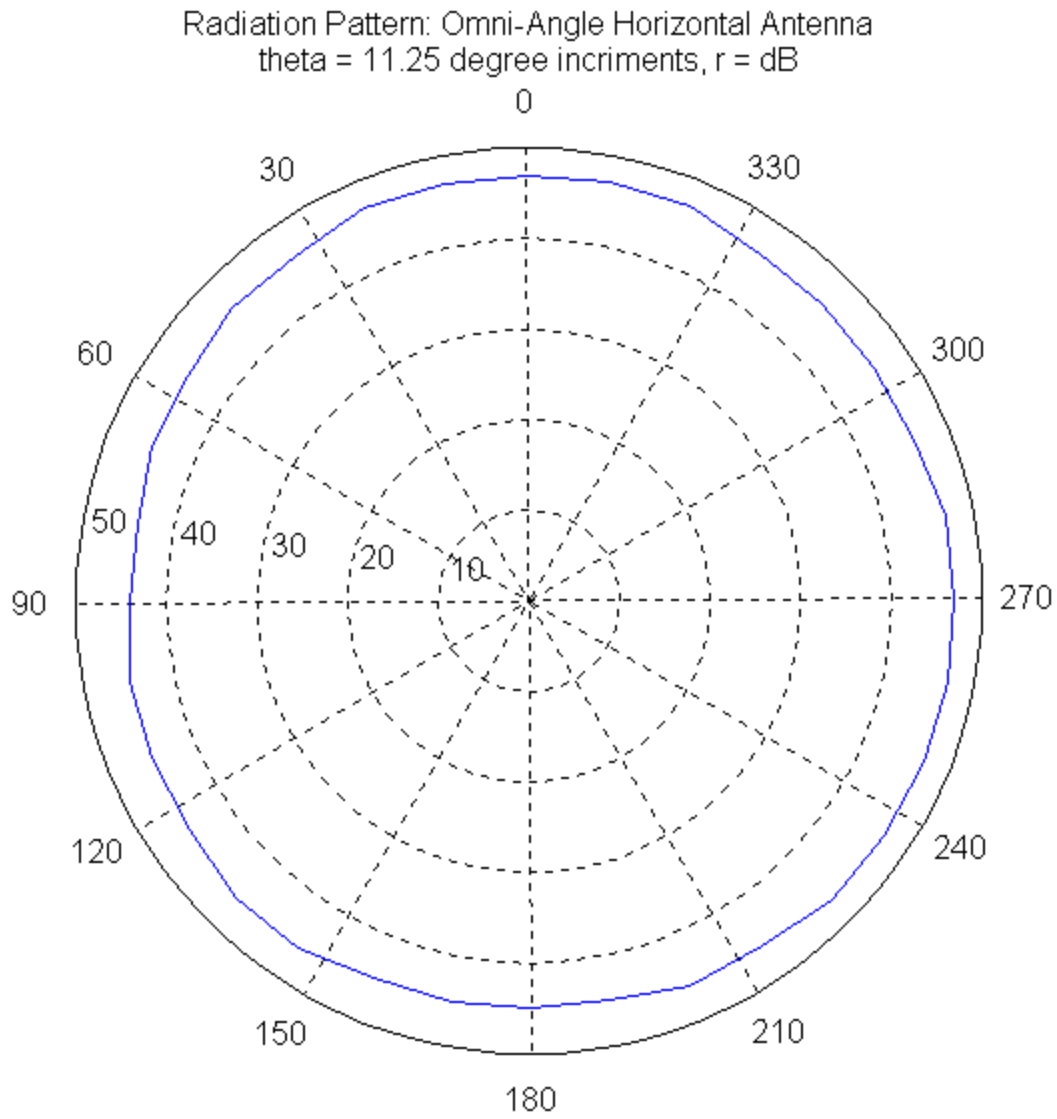

Observe the uniform circular pattern. The antenna is truly omni-directional and offers no gain.

II.) Sample Raw Data for Radiation Pattern Measurements

θ (degrees)	dB
0	57
11.25	57
22.5	57
33.75	56
45	56
56.25	54
67.5	51
78.75	51
90	50
101.25	49
112.5	36
123.75	33
135	36
146.25	33
157.5	31
168.75	27
180	34
191.25	36
202.5	35
213.75	35
225	34
236.25	35
247.5	37
258.75	40
270	43
281.25	44
292.5	47
303.75	51
315	54
326.25	57
337.5	57
348.75	57
360	57

III.) Known Error Sources

The following error sources were identified during this lab experiment:

- 1.) The reflective bodies of automobiles caused fluctuations in readings.
- 2.) The movement of people around the field caused fluctuations in readings.
- 3.) The movement of birds and leaves caused fluctuations in readings.
- 4.) Movement of the attenuator caused fluctuations in readings.
- 5.) The mast and rotator box altered some of the radiation patterns.
- 6.) The movement and positioning of the coaxial cable altered patterns.
- 7.) Mis-mounting of the antennas caused altered patterns.
- 8.) The increasing temperature of the transmitter lowered dB levels.
- 9.) Operator error.
- 10.) Antenna design issues.

Group Photograph:



*From left to right:
Huy Nguyen, Nicholas Blas, Vishal Bhavsar*